

Features

- Hermetic 6-pin TO-5 package
- 1000Vdc isolation voltage
- High CTR
- High reliability and rugged construction
- High reliability screening available
- Radiation tolerant
- DC input with transistor output
- Operating temperature range -55°C to +125°C

Applications

- Switch mode power supplies
- Computer peripheral interface
- Motor control
- Ground signal isolation

Description

The IBH249 consists of a phototransistor optically coupled to an AlGaAs infrared-emitting diode in a hermetic TO-5 package.

Schematic Diagram

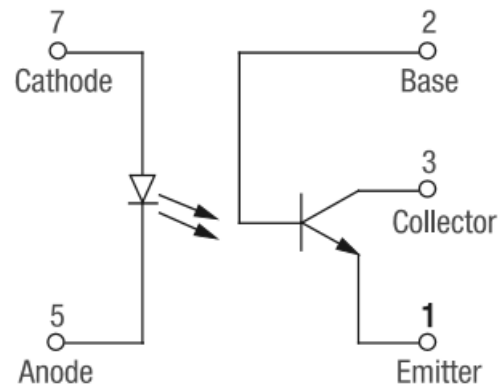

Figure 1. IBH249 Schematic Diagram

Package Dimensions in inches (mm)

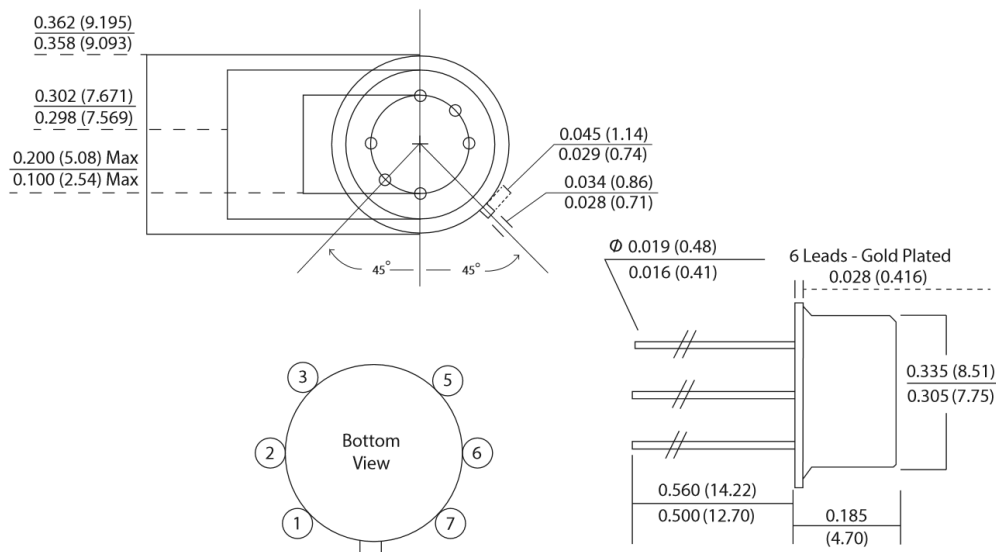

Figure 2. IBH249 Package Dimensions

Absolute Maximum Rating at 25°C (Note 1)

Symbol	Parameters	Ratings	Units	Notes
V _{DC}	Isolation voltage	-1000 to +1000	V	2
T _{OPR}	Operating temperature	-55 to +125	°C	
T _{STG}	Storage temperature	-65 to +150	°C	
T _{SOL}	Soldering temperature (10 seconds maximum)	240	°C	
Emitter				
P _D	Emitter power dissipation	60	mW	
I _F	Forward current	40	mA	3
I _{F(TRANS)}	Peak transient current (≤1μs P.W., 300pps)	1	A	
V _R	Reverse voltage	2	V	
Detector				
P _D	Detector power dissipation	300	mW	4
V _{CE}	Collector-Emitter Voltage	40	V	
V _{EB}	Emitter-Base Voltage	7	V	
V _{CB}	Collector-Base Voltage	45	V	
I _{CC}	Continuous Collector Current	50	mA	

Notes

1. When using this product, please observe the absolute maximum ratings. Only one parameter may be set at the limit to ensure no damage to the device. Exceeding any of the limits listed here may damage the device.
2. Measured between input pins 5, 6, and 7 shorted together, and output pins 1, 2, and 3 shorted together. T_A = 25°C and duration = 1sec.
3. Linear derating factor: 0.67 mA/°C above 65°C
4. Linear derating factor: 3.0 mW/°C above 25°C

ESD Precaution

Please be advised that normal static precautions should be taken in the handling and assembly of this device to prevent damage or degradation which may be induced by electrostatic discharge (ESD).

Electrical Characteristics $T_A = 25^\circ\text{C}$ (unless otherwise specified) (Note 1)

Emitter Characteristics

Symbol	Parameters	Test Conditions	Min	Max	Units	Notes
V_F	Forward Voltage	$I_F=10\text{mA}$, $T_A = -55^\circ\text{C}$	1.4	2.0	V	
		$I_F=10\text{mA}$	1.2	1.8	V	
		$I_F=10\text{mA}$, $T_A = 100^\circ\text{C}$	1.1	1.7	V	
I_R	Reverse Current	$V_R = 2\text{V}$	-	100	μA	

Detector Characteristics

Symbol	Parameters	Test Conditions	Min	Max	Units	Notes
BV_{CEO}	Collector-Emitter Breakdown Voltage	$I_{CE}=1\text{mA}$	40	-	V	
BV_{CBO}	Collector-Base Breakdown Voltage	$I_{CB}=100\mu\text{A}$	45	-	V	
BV_{EBO}	Emitter-Base Breakdown Voltage	$I_{EB}=100\mu\text{A}$	7	-	V	
I_{C_ON}	Collector Current, On-state	$V_{CE}=5\text{V}$, $I_F=1\text{mA}$	2.0	12.0	mA	
		$V_{CE}=5\text{V}$, $I_F=2\text{mA}$, $T_A = -55^\circ\text{C}$	2.8	-	mA	
		$V_{CE}=5\text{V}$, $I_F=2\text{mA}$, $T_A = 100^\circ\text{C}$	2.0	-	mA	
I_{CB_ON}	Collector Base Current, On-state	$V_{CB}=5\text{V}$, $I_F=10\text{mA}$	30	-	μA	
I_{CE_OFF}	Collector-Emitter Dark Current, Off-state	$V_{CE}=20\text{V}$	-	100	nA	
		$V_{CE}=20\text{V}$, $T_A = 100^\circ\text{C}$	-	100	μA	
I_{CB_OFF}	Collector-Base Dark Current, Off-state	$V_{CB}=20\text{V}$	-	10	nA	

Transfer Characteristics

Symbol	Parameters	Test Conditions	Min	Max	Units	Notes
$V_{CE(SAT)}$	Collector-Emitter Saturation Voltage	$I_F=2\text{mA}$, $I_C=2\text{mA}$	-	0.3	V	
R_{IO}	Isolation Resistance	$V_{IO}=\pm 1000\text{V}_{DC}$	10^{11}	-	Ω	2
C_{IO}	Isolation Capacitance	$f=1\text{MHz}$, $V_{IO}=0\text{V}_{DC}$	-	5	pF	2

Switching Characteristics

Symbol	Parameters	Test Conditions	Min	Max	Units	Notes
t_r	Rise Time	$I_F=5\text{mA}$, $V_{CC}=10\text{V}$, $R_L=100\Omega$	-	25	μs	
t_f	Fall Time		-	25		

Notes

- Performance guaranteed only under conditions listed in above tables.
- Measured between input pins 5, 6, and 7 shorted together, and output pins 1, 2, and 3 shorted together. $T_A = 25^\circ\text{C}$ and duration = 1sec.

Typical Characteristic Curves

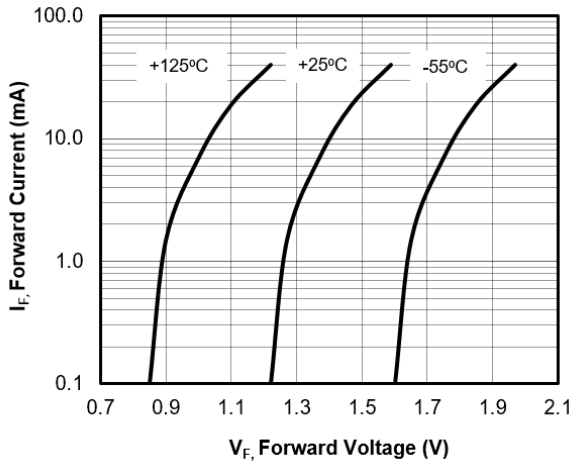
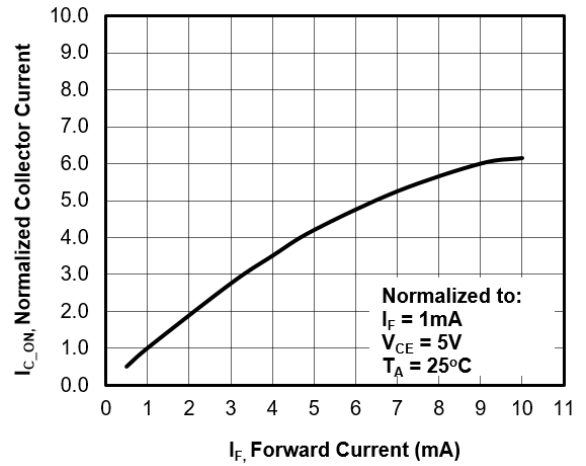
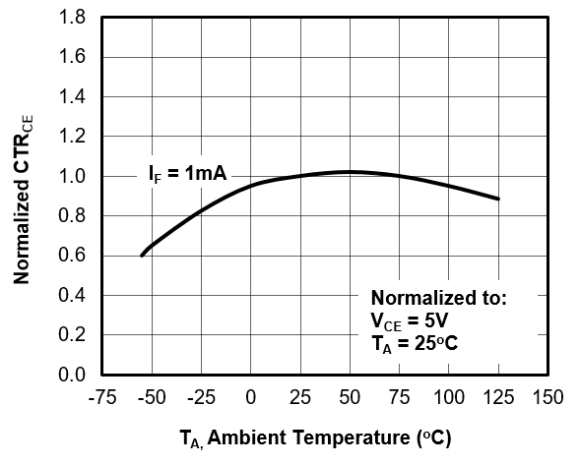
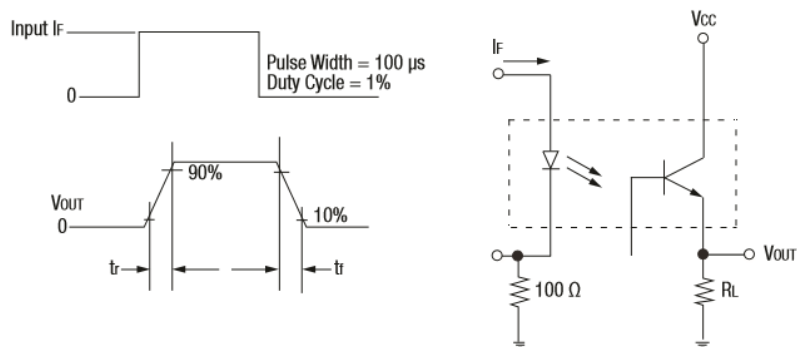
Figure 3. Forward Current vs Forward Voltage

Figure 4. Collector Current vs Forward Current

Figure 5. Normalized CTR_{CE} vs Temperature

Figure 6. IBH249 Switching Test Circuit



Ordering Information

<i>Manufacturing Part Number</i>	<i>Part Description</i>
IBH249	Radiation Tolerant Phototransistor Hermetic 6-pin TO-5 Package

DISCLAIMER

Isobaud Inc. reserves the right to make changes without further notice to any products herein to improve reliability, function or design. Isobaud Inc. does not assume any liability arising out of the application or use of any product or circuit described herein; neither does it convey any license under its patent rights, nor the rights of others.